

# Historic **ACROPOLIS** Rally'24



by N. P. P. P.

## RALLY GUIDE ΟΔΗΓΟΣ ΑΓΩΝΑ



SPORTING



# FIA EUROPEAN HISTORIC RALLY CHAMPIONSHIP

## HISTORIC ACROPOLIS RALLY 2024

### RALLY GUIDE

#### INDEX

<b>1 INTRODUCTION – WELCOME .....</b>	<b>3</b>
<b>2 CONTACT DETAILS .....</b>	<b>4</b>
<b>3 PRESS OFFICE – MEDIA INFORMATION/ACCREDITATION .....</b>	<b>4</b>
<b>4 PROGRAMME DURING THE RALLY WEEK .....</b>	<b>5</b>
<b>5 IMPORTANT INFORMATION BEFORE THE START OF THE RALLY .....</b>	<b>6</b>
<b>6 IMPORTANT INFORMATION DURING THE COMPETITION .....</b>	<b>7</b>
<b>7 PODIUM FINISH AND PRIZE GIVING .....</b>	<b>8</b>
<b>8 GENERAL INFORMATION .....</b>	<b>9</b>
<b>9 ITEA .....</b>	<b>12</b>
<b>10 SIGHTSEEING IN CENTRAL GREECE.....</b>	<b>14</b>
<b>11 WINNERS .....</b>	<b>18</b>
<b>11 APPENDIX A.....</b>	<b>20</b>



## 1. INTRODUCTION – WELCOME

Dear participants, dear friends of motorsport, dear spectators,

It is with great pleasure and emotion that I welcome you to Historic Acropolis Rally 2024, a race that has captured the hearts of fans of historic cars and rally racing, not only in Greece, but all over the world. The Historic Acropolis Rally is a landmark that fills us with pride and honour, has become an integral part of motor sport, and bears the special stamp of Greek hospitality and the demanding Greek nature.

The Historic Acropolis Rally is not just a race, it is a living part of the global heritage of motorsport. The automotive legends of the past and its historic routes are deeply engraved in the memory and heart of every racing enthusiast. Every turn, every jump and every special moment is part of our history, a history full of thrills, challenges and successes.

The Historic Acropolis Rally is a celebration for all of us who love motorsport and an opportunity to honour the past while looking to the future.

I would like to thank everyone who has contributed to the organization and implementation of this year's race. In particular, I would like to thank the volunteers, the State authorities and of course our sponsors; without their support the race would not have been possible. The contribution of all of you is crucial and I am sure that, as every year, this event will be a success, offering unique moments to all participants and spectators.

Greece, through the Historic Acropolis Rally, promotes the unparalleled beauty of nature and its rich cultural heritage throughout the world. Our routes, which pass through areas of natural beauty and cultural interest, give our visitors the opportunity to experience another side of our country, far from the urban centres, but full of authenticity, history and traditions.

I wish all crews good luck and safe stages. I am sure that this year's event will offer us strong emotions and indelible moments.

With these thoughts, declaring the start of the Historic Acropolis Rally, I invite you to enjoy this unique race, where the past and the present of motorsport come together, creating an unforgettable spectacle.

Good luck to all!

Dimitris Michelakakis

President of Hellenic Motorsport Federation



## 2. CONTACT DETAILS

### Permanent Organisation Contact Details

#### Rally H.Q.

**MONDAY 04.11 – THURSDAY 07.11.2024**

#### Venue Location Athens

Hellenic Motorsport Federation – OMAE

Address: 1 Spyrou Loui Avenue – OAKA – Velodrome (Gate ΣΤ') - Maroussi

Tel: +30 210 6892000

E-Mail: [info@omae-epa.gr](mailto:info@omae-epa.gr)

Web: [www.historicacropolis.gr](http://www.historicacropolis.gr)

GPS coordinates: 38.04028, 23.78029

#### Rally H.Q.

**FRIDAY 08.11 – SUNDAY 10.11.2024**

#### Venue Location Itea

TROCADERO BOUTIQUE HOTEL

Address: 2 Athanasiou Diakou str, Itea

Tel.: +30 2265033413

<https://www.hoteltrokadero.com/>

E-Mail: [fia\\_office@omae-epa.gr](mailto:fia_office@omae-epa.gr)

GPS coordinates: 38.43510, 22.42040

## 3. PRESS OFFICE – MEDIA INFORMATION/ACCREDITATION

### THURSDAY 07.11.2024

Hellenic Motorsport Federation – OMAE

Address: 1 Spyrou Loui Avenue – OAKA – Velodrome (Gate ΣΤ') – Maroussi

Tel: +30 210 6892000

E-Mail: [info@omae-epa.gr](mailto:info@omae-epa.gr)

Web: [www.historicacropolis.gr](http://www.historicacropolis.gr)

GPS coordinates: 38.04028, 23.78029

E-mail: [pressomaeoffice@gmail.com](mailto:pressomaeoffice@gmail.com)

Opening hours: 10:00 – 22:00

### FRIDAY 08.11 – SUNDAY 10.11.2024

#### Venue Location Itea

TROCADERO BOUTIQUE HOTEL

Address: 2 Athanasiou Diakou str, Itea

Tel.: +30 2265033413

<https://www.hoteltrokadero.com/>

GPS coordinates: 38.43510, 22.42040

E-mail: [pressomaeoffice@gmail.com](mailto:pressomaeoffice@gmail.com)



#### Opening hours

Friday	08.11.2024	10:00 – 23:30
Saturday	09.11.2024	08:30 – 23:30
Sunday	10.11.2024	07:30 – 20:00

#### **4. PROGRAMME DURING THE RALLY WEEK**

Please, find the programme in the Supplementary Regulations at [www.historicacropolis.gr](http://www.historicacropolis.gr) and in the Sportity mobile application (password: [ACRHIST24SP](#) or [ACRHIST24LE](#) or [ACRHIST24RE](#)).

#### **4.1 LOCATION AND CONTACT DETAILS OF THE RALLY WEEK**

##### **Rally office location from Monday 4.11.2024 – Thursday 07.11.2024**

Hellenic Motorsport Federation (OMAE), 1 Spyrou Loui Avenue – OAKA Velodrome – Maroussi  
Tel. +30 210 6892000

e-mail: [info@omae-epa.gr](mailto:info@omae-epa.gr)

web: [historicacropolis.gr](http://historicacropolis.gr)

GPS coordinates: 38.04028, 23.78029

<u>Opening hours:</u>	Monday	04.11.24	08:00 – 20:00
	Tuesday	05.11.24	08:00 – 20:00
	Wednesday	06.11.24	08:00 – 20:00
	Thursday*	07.11.24	08:00 – 22:30

\* The administrative checks will be held at The Peace and Friendship Stadium, 1 Ethnarhou Makariou street, Neo Faliro (GPS coordinates: 37.94321, 23.66921 – SPORTITY ([ACRHIST24SP](#) or [ACRHIST24LE](#) or [ACRHIST24RE](#)) – Tel.: +30 693 6512 926)

##### **Rally HQ location from Friday 08.11.2024 – Sunday 10.11.2024**

Trokadero Hotel

Address: Athanassiou Diakou 2 str, Itea

Tel.: +30 2265033300

GPS coordinates: 38.43510, 22.42040

<u>Opening hours:</u>	Friday	08.11.24	08:00 – 20:00
	Saturday	09.11.24	07:30 – 23:30
	Sunday	10.11.24	07:00 – 20:00

#### **4.2 OFFICIAL NOTICE BOARD**

Virtual Notice Board (VNB) is online at Sportity mobile application (password: [ACRHIST24SP](#) or [ACRHIST24LE](#) or [ACRHIST24RE](#)) and [www.historicacropolis.gr](http://www.historicacropolis.gr)



#### 4.3 COMPETITORS' RELATION OFFICERS



**NAME: FILIPPOS PAPASTATHOPOULOS**  
Tel.: +30 6932155385  
Languages: ENGLISH – JAPANESE – GERMAN

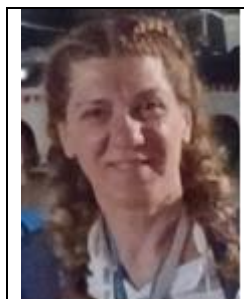

**NAME: KONSTANTINA KARAMANIDOU**  
Tel.: +30 693 6513 417  
Languages: ENGLISH

The COMPETITORS' RELATIONS OFFICERS will be identifiable by a red tabard with text CRO.

The CROs will be present at the Administrative Checks, Scrutineering, Opening Ceremony, Service Park, Regrouping areas, and Finish.

A detailed CROs' Schedule will be posted on the Official Notice Board, on the event website and will also be provided to Competitors during Administrative Checks.

### 5. IMPORTANT INFORMATION BEFORE THE START OF THE RALLY

#### 5.1 ADMINISTRATIVE CHECKING

**Thursday 07.11.2024**

The Peace and Friendship Stadium  
1 Ethnarhou Makariou street, Neo Faliro  
Tel.: +30 693 6512 926  
Hours: 14:00 – 20:00  
E-Mail: [info@omae-epa.gr](mailto:info@omae-epa.gr)  
Web: [www.historicacropolis.gr](http://www.historicacropolis.gr)  
GPS coordinates: 37.94321, 23.66921

#### 5.2 DOCUMENTS TO BE PRESENTED

At Administrative Checking the following documents will be checked, and entry form details will be verified:

- Competitor's licence
- Driver and Co-driver competition licences
- Driver and Co-driver valid driving licences
- ASN authorisation (mandatory for all foreign Competitors and/or Drivers)



- Completion of all details on the entry form
- Valid personal accident insurance for non-EU Drivers
- Car registration papers (Technical Passport (HTP/ΔΤΤ), Car Registration, Insurance Policy, Green Card, etc. where appropriate)
- Valid car's FIA HTP

### **Administrative Check will take place as follow:**

Thursday 07.11.2024 14:00 – 20:00

Please find the information in the Supplementary Regulations

### **5.3 RALLY SAFETY TRACKING SYSTEM AND TIMING TRANSPODER**

Please find the information in the Supplementary Regulations

#### Collection of the Tracking System:

**Thursday 07.11.2024 14:00 -20:00 from the Scrutineering venue**

The competitors have to deposit the amount of 100 euros as a guarantee, which will be returned in full upon the return of the tracker.

#### Returning the Tracking System:

**Sunday 10.11.2024 – Rally finish**

The device will be returned after finish.

If any problems occur with the Safety Tracking Device during the reconnaissance or the competition, please contact Trail Track, Mr. Katsimalis, tel. +30 697 592 3759

Installation instructions: see APPENDIX A

## **6. IMPORTANT INFORMATION DURING THE COMPETITION**

### **6.1 START OF THE COMPETITION**

List of crews admitted, starting and exact start times will be published in the Official Notice Board SPORTITY (ACRHIST24SP or ACRHIST24LE or ACRHIST24RE).

For the timecards, please see in the Supplementary Regulations.

### **6.2 SERVICING AND SERVICE AREAS**

Competitors and their service crews are expected to handle fuel, oil, and other liquid substances very carefully. Ground protective sheets, which can absorb oil and gas, must be placed under rally cars and service cars whenever servicing.

### **6.3 REFUELLING**

Refueling is allowed only on refuelling zones (RZ) and on commercial fuel stations marked in Road Books. Competitors' cars may be refuelled in RZ from their own petrol cans with team's





help or from the commercial fuel stations with commercially available fuel without any help from the team members (FIA Appendix K, article 3.9).

Refueling is strictly prohibited on Service Parks and on road sections (excluding the refuelling zones marked in Road Books). The engine must be stopped, and crew should remain outside the car during refueling. If crew stays in the car safety belts must not be affixed.

Competitors are responsible to protect the ground with an Absorbent Mat or Environmental Spill Kit which shall be composed of an absorbent upper part and an impermeable lower part. Two team members may access the RZ to assist each crew. The personnel assisting refueling must be wearing clothing which will provide adequate protection against fire and includes at least: long trousers, long-sleeved top, closed shoes, a balaclava, and gloves. Competitors are solely responsible for the refueling.

For safety reasons, fuel tank must be as empty as possible when entering Parc Fermé.

#### **6.4 STOPPING ON SPECIAL STAGE – SOS/OK SIGNS**

Competitors must use the SOS sign to get medical assistance for injured persons. The marshals have been instructed of its meaning. Show it to the marshals and to fellow competitors, so that they will know to call for help. If you see this sign given by another competitor, please give the message to the closest possible place (on Special Stages marked radio points or start/finish). If you are not requiring any medical help, place the OK sign on the car visible for other competitors.

#### **6.5 RETIREMENT**

If the crew must retire from the competition, they must immediately notify the HQ Rally Control Center. The telephone number can be found in the Road Books. Please remember to collect your FIA HTP from the Rally HQ in case of retirement. Vehicles left along a special stage, can be picked up only after the SS has been opened to public traffic, unless permitted earlier by the Rally Control Center.

##### **6.5.1 RE-START AFTER RETIRMENT**

Please see in the Supplementary Regulations.

#### **7. PODIUM FINISH AND PRIZE GIVING**

The podium finish will be located in front of pier, at Itea port, 28 October street, and the prize giving will be on the ramp.

The Drivers must pass the last Time Control TC 11A to be classified.

Drivers are not allowed to leave their cars before prize-giving to ensure that cars could be arranged in the correct order without any problems. From the holding area, marshals will guide the competitors to the podium finish where the awards will be given. The crews positioned 3rd to 1st overall will drive to finish podium first and they will be interviewed.





The rest of the crews will drive through the podium and after to parc fermé.  
The category and class awards will be given during the prize giving on the ramp.

**Please notice that the competition cars are under Parc Fermé regulations all the time from the TC 11A to the end of Parc Fermé. The Parc Fermé will be opened when final classifications have been published.**

## 8. GENERAL INFORMATION

### 8.1 HELP DESK

For any kind of information or assistance with bookings, reservations etc. you may contact [fia\\_office@omae-epa.gr](mailto:fia_office@omae-epa.gr) (Ms. Kostala / Ms. Vrettou).

### 8.2 HOTELS IN THE AREA AROUND THE OLYMPIC ATHLETIC CENTRE (OAKA)

#### **CIVITEL ESPRIT/ATTIK ROOMS & SUITES** 1.6 km from OAKA

Address: 11 Olympias street, Maroussi, ZIP code: 15124

Tel.: +30 210 6101000

[www.civitelattik.gr](http://www.civitelattik.gr)

#### **HOTEL MAROUSHI** 1.6 km from OAKA

Address: 10 Olympias street, Maroussi, ZIP code: 15124

Tel.: +30 210 6198338

[www.lightskyhotels.gr](http://www.lightskyhotels.gr)

#### **OLYMPIC FASHION HOTELS** 1.7 km from OAKA

Address: 1 Souris street, Chalandri, ZIP code: 15232

Tel.: +30 210 6813430

[www.fashionhotels.gr](http://www.fashionhotels.gr)

#### **CHROMA FASHION HOTEL** 1.3 km from OAKA

Address: 5 Pentelis Ave., Chalandri, ZIP code: 15233

Tel.: +30 210 6800036

[www.fashionhotels.gr](http://www.fashionhotels.gr)

#### **ELEMENTS ROOMS & APARTMENTS** 1,6 km from OAKA

Address: 1 Makedonias street, Chalandri, ZIP code: 15233

Tel.: +30 210 6825530

[www.elementsrooms.gr](http://www.elementsrooms.gr)

#### **COCO-MAT HOTEL NAFSIKA** 3,2 km from OAKA

Address: 6 Pellis street, Kifisia, ZIP code: 145 61



Tel.: +30 210 8018027

[www.nafsika.gr](http://www.nafsika.gr)

### 8.3 CARGO TRANSPORTATION AND FERRY BOOKINGS

For your cargo transportation and ferry bookings, you may contact SUPPRFAST FERRIES. They are sailing from/to Ancona, Venice, Bari, Igoumenitsa or Patras, and will provide a discount of 30% to foreign crews participating in the Historic Acropolis Rally 2024 for the dates from 01.11.24 to 11.11.24.

#### Order Number: 24/416/O30/IP

For reservations you may contact:

For passengers, cars, trailers:

Tel.: +30 210 8919200

Fax: +30 210 8919938

E-mail: [callcenter@attica-group.com](mailto:callcenter@attica-group.com)

For trucks:

Tel.: +30 210 8919710

Fax: +30 210 8919719

E-mail: [adriatic.cargo.capacity@anek-superfast.com](mailto:adriatic.cargo.capacity@anek-superfast.com)

**Please make sure that your registration has been accepted before you proceed with the reservations.**

### 8.4 MEDICAL INFORMATION

Itea Health Center, Ep. Papaleksandri Str., Itea

Tel: +30 2265 351000

Amfissa General Hospital, Oikismos (meaning settlement) Drossochoriou, Amfissa

Tel: +30 22650 22222

### 8.5 EMERGENCY NUMBERS

Ambulance: 166

POLICE: 100

FIRE DPT: 199

### 8.6 TRAFFIC INSURANCE

All vehicles entering Greece must have a valid green card (traffic insurance)

### 8.7 TRAFFIC RULES

- Drive on the right side, overtake on the left.



- Drivers and all passengers are required to use front and rear seat belts at all times and motorcyclists to wear helmets.
- Drivers must carry their driving license at all times.
- Drunk drivers are liable to heavy penalties that may go as far as imprisonment. The legal blood alcohol limit for driving is 0.25 mg/l (breath test) or 0,5 g/l (blood test). The police may stop motorists randomly to take a breathily test. If you are asked you should comply.

### 8.8 SPEED LIMITS

- Built up areas 30 km/h
- Main roads 110 km/h
- Motorways 130 km/h

### 8.9 CIRCULATION ON THE PATRAS – CORINTH – ATHENS AND ON THE ATHENS – LAMIA – THESSALONIKI MOTORWAYS FOR VEHICLES OVER 1.5 TONS PAYLOAD

During weekends, there are restrictions in force on the circulation of heavy vehicles, on the Athens - Corinth - Patras (Olympia Odos), Athens - Lamia Motorways (Nea Odos) and Egnatia Odos as follows:

On Fridays, exiting Athens towards Corinth - Patras or Lamia, from 16:00-21:00. On Sundays, entering Athens from Patras, Corinth or Lamia, from 15:00-22:00. No restrictions are in force on Saturdays. Competitors must respect the above restrictions

### 8.10 PASSPORTS

Citizens of the EU countries that have signed the Schengen Agreement may enter Greece with either an identity card or a passport. Citizens from all the other countries may enter Greece with their passport, and visa if required. See <https://www.mfa.gr/en/visas/visas-for-foreigners-traveling-to-greece/countries-requiring-or-not-requiring-visa.html>

### 8.11 AIRPORT INFORMATION

Athens airport, "ELEFTHERIOS VENIZELOS INTERNATIONAL" (EL. VENIZELOS), is in Spata. For all International Airlines, Aegean & Olympic Airlines please dial the Main Terminal switchboard: +30 210 35 30 000

Transportation from the airport to the city of Athens is by taxi, metro or bus.

### 8.12 CURRENCY

Greek currency is the EURO (€)

### 8.13 TELEPHONE CALLING CODE

+30



## 8.14 CLIMATE

Autumn in Greece is mild, with average temperature fluctuating between 12°C and 22°C in the beginning of November. The sun shines almost all day except from the few rainy days.

## 8.15 TIME ZONE

Greenwich Meantime GMT + 3 hours

## 8.16 LANGUAGE

Greek. English is spoken.

## 8.17 POWER SUPPLY

The electricity current is 220V (volts). Plugs and sockets are the same as in the continental countries of the European Union, two-pin plug.

## 8.18 BANKS

Banks' opening hours are Monday to Friday from 08:00 to 14:00. All banks use ATM machines, open 24/7. Most banks display exchange rates on their windows.

## 8.19 CREDIT CARDS

All major credit cards are widely accepted in hotels, restaurants, supermarkets, stores etc.

## 8.20 RENT A CAR

AVIS

- Athens Airport, tel.: +30 210 3530579 (24/7)
- Athens (23 Syngrou Ave.), tel.: +30 210 3224951 (08:00-21:00)

HERTZ

- Athens Airport, tel.: +30 210 3534900 (07:00- 23:00)
- Athens (25 Syngrou Ave.), tel.: +30 211 1084400 (08:00-20:30)

EUROPCAR

- Athens Airport, tel.: +30 211 1903000 (24/7)
- Athens (28 Syngrou Ave.), tel.: +30 211 1903004 (08:30-20:30)

## 9. ITEA

### 9.1 SHOPS WORKING HOURS

Every day open from 09:00- 14:30 and 18:00-20:30 except Wednesday and Saturday. (Sunday: closed)

### 9.2 PHARMACIES

#### Working Hours

Monday, Tuesday, Thursday, Friday: open from 09:00- 14:30 and 18:00-20:30  
Wednesday and Saturday: open from 09:00- 14:30



Sunday: closed

There is always a pharmacy open for emergencies (you will find emergency pharmacy details in every pharmacy window per day).

Close to the HQ you will find the following pharmacies:

**PHARMACY Polyzois Panagiotis**  
Address: 28<sup>th</sup> Oktovriou Street & Iroon, Itea  
Tel: +30 226 503 3777

**PHARMACY Raptis Georgios & Athanasios**  
Address: 67 28<sup>th</sup> Oktovriou Street, Itea  
Tel: +30 226 503 3213

### 9.3 SUPER MARKETS

Working Hours: Monday-Friday 08:00 – 21:00, Saturday 08:00-20:00 (Sunday: closed)

Close to the HQ you will find the following:

**SKLAVENITIS**  
Address: 33 Ilia Triga Str., Itea  
Tel.: +30 226 503 5270

**MY MARKET**  
Address: 5 Iroon & Kapodistriou Str., Itea  
Tel.: +30 226 503 2151

### 9.4 FUEL STATIONS

Working Hours: 07:30 - 21:00

**SHELL**  
Address: 47 Metamorfoseos Str., Itea  
Tel.: +30 226 503 2231  
Mobile: +30 694 858 2017

**EKO**  
Address: 1<sup>st</sup> km Iteas – Amfissas National Road  
Tel.: +30 226 503 2272  
Mobile: +30 697 842 7269  
Automated Fuel Dispenser: 24/7 (only by credit card – no contactless transactions)



## 9.5 BANKS / AUTOMATED CASH MACHINE

National Bank of Greece

Address: 61 28<sup>th</sup> Oktovriou Street, Itea

Tel.: +30 226 503 6011

Working Hours: Monday-Friday 08:00 – 14:00 (Saturday & Sunday: closed)

Automated Cash Machine:

Near the Rally Office and the Park Fermé, in Itea (24/7)

## 9.6 TAXI SERVICE

ITEA TAXI tel.: +30 698 323 8808

TAXI FOKIDA tel.: +30 694 498 8038

## 10. SIGHTSEEING IN CENTRAL GREECE

### 10.1 THE ARCHAEOLOGICAL SITE OF DELPHI

At the foot of mount Parnassos, in the evocative natural landscape formed between two majestic rocks, Phaedriades, is the Panhellenic sanctuary of Delphi and the most famous oracle of ancient Greece.

Delphi was the navel of the earth, where, according to mythology, the two eagles sent by Zeus from the ends of the universe to find the center of the world met, and, for many centuries, it was the spiritual and religious center and symbol of the unity of ancient Hellenism.

### 10.2 ITEA

The coastal town of Itea is located 13 km south of Amfissa, embraced by the Corinthian Gulf. Together with the neighbouring Kirra, it is built around Crissae Gulf.

Behind the picturesque Itea, lies the olive grove of Amfissa, surrounded by the beautiful mountains of Giona and Parnassos, on which you can see Delphi and Chrissos.

### 10.3 THEBES (THIVA)

Thebes is the 3rd oldest city of Europe and it was built by Cadmus, according to the myth. Epameinondas was one of the most prominent Thebans, the great general of the 4th century BC, who transformed the Ancient Greek city-state of Thebes into a pre-eminent position in Greek politics called the Theban Hegemony. The Acropolis of Thebes was named Cadmea, after its founder.

### The Archaeological Museum of Thebes

The Archaeological Museum of Thebes is one of the most important archaeological museums in Greece, as some of its collections are rare or unique in their kind. Its exhibits come from





excavations in Voiotia and chronologically cover the culture of the region from the Palaeolithic to the post-Byzantine period.

#### 10.4 DISTOMO

The town of Distomo is located in southwest of Livadia, built on a plain between the mountains Kirfi, Parnassos and Helicon. It is 25 km from Thebes and 160 km from Athens.

Distomo is remembered in history as a martyr town because of the massacre in 1944. Today, near the entrance of the town, there is the Museum of Victims of Nazism, which presents the full history of the place through documents and photographs. Also, on the Kanales Hill is the Mausoleum of the victims of 1944. In the Distomo Museum Collection there are exhibits from the wider region, from the Mycenaean to the early Christian period.

#### 10.5 ARACHOVA

Arachova is built on a slope of Parnassos, which ends in a gorge, at the bottom of which flows the river Pleistos. The average altitude of the town is 950 metres. The town is located on the main road connecting Delphi and Thebes from ancient times and the plain of Amfissa with Voiotia. Its location on an important pass helped the development of Arachova to a greater extent than its neighbours. The town is 12 kilometres from Delphi, which lies further west, and 160 kilometres from Athens.

#### 10.6 AKRAIFNIO

##### **The Church of Saint George of Akraifnio**

The church of St. George is located at the southern end of the settlement of Akraifnio, on the foothills of Vigliza (or Skopia) hill, where extensive remains of the ancient acropolis of two building phases, the 4th century BC and the Hellenistic period, are preserved. It is estimated that the ancient temple of Dionysus existed on the site of the Christian monument.

A number of ancient parts and stone inscriptions have been used as building material in the construction of the building.

From the walls of the main temple, three marble columns of great archaeological value, with extensive inscriptions of the Roman period (1st century AD), which were engraved under the supervision of Epameinondas Epameinondou, citizen of ancient Akraifnia, have been removed and are in the museum of Thebes.

a) The first includes the "Panhellenians" resolution to send a delegation to Rome, to congratulate the new emperor Gaius Germanicus (Caligula) and the emperor's letter of thanks to the Greeks ("Panhellenians").

b) The second includes the speech delivered by Nero at Corinth (Isthmia), in 67 AD, in which he granted freedom to the Greeks and exemption from taxes, as well as the honours paid by the Acraifnians to the emperor.



c) The third includes Epameinondas' social contribution to his fellow citizens, the Acraifnians, the Boeotians, and the Greeks in general.

### "Sarakino" prehistoric cave

At the 103rd km of Athens-Lamia highway and 300 m west of Akraifnio-Aliarto junction, high on the rocky hill that rises north of the parallel road, is located one of the most beautiful caves of Central Greece and certainly the most important cave of Boeotia. This is Sarakinos or Sarakenos or Sarakiniko cave.

It is located at an altitude of 190 m, i.e. 100 m above the plain. It is a cave of large dimensions, with an area of 3,000 square metres, with a long (30 m) and high arched entrance that provides natural lighting, which could be used for habitation, storage, burial, etc., with a magnificent view of Copaida lake and 40,000-year-old findings.

An interesting fact about this cave is that it was continuously inhabited until 1600 BC and is literally a monument of the human presence on earth.

### ACROPOLIS OF ACRAIFNIA

The Acropolis of ancient Akraif(n)ia is located south of the village of Akraifnio on Vigliza (or Skopia) hill. Part of the fortification of the 4th century BC as well as a tower of pentagonal plan with a gate are the remains of the Acropolis. Ancient building material and inscriptions from the Acropolis, are embedded in the church of Agios Georgios (Saint George).

### SANCTUARY OF PTOOS APOLLON

The Sanctuary of Ptoos Apollon is located three kilometers east of Akraifnio, on Pelagia Mountain. The sanctuary was dependent on Thebes and was already famous in Archaic times (7th century BC). The new temple dates back to the end of the 4th century BC. It consisted of a temple (of Archaic and then Hellenistic times) around which there were votive statues of young men (Kouroi) and tripods. At lower levels, there were galleries, a guest house, a large cistern and a source of prophecies (oracle).

In the area, there was an oracle, which was famous throughout Boeotia. Every five years, musical competitions ("Ptoia"), were organized. The competitions were combined with religious ceremonies and sacrifices. Statues of Kouros, bronze offerings, vases, utensils and many statuettes dedicated to Apollon, have been found in the sanctuary.

### HERO PTOOS SANCTUARY

The neighbouring sanctuary of the hero Ptoos, at Kastraki, was founded in the 6th century BC by the city of Akraifnia and was abandoned at the end of the 4th century BC. A sacred road, flanked by two rows of bronze tripods, connected the city with the sanctuary.

### Yliki Lake

Yliki is a natural lake in Boeotia. It is also called Likeri and has an area of about 19.1 square kilometres. There is also a settlement with the same name, Yliki.



In antiquity, Yliki was pronounced in a way similar to the city of Yli, which was built on its shores, as well as the city of Akraif(n)ia. Its waters flowed into the neighbouring Trefia or Ougria lake, named Paralimni in modern times. Very close to Yliki there was a large temple of Apollon, which was called "Ptoos" after the neighbouring mountain with the same name. In the past, the water of the lake was used to supply the city of Athens with water.



## 11. WINNERS

2002

Sporting: Konstantinos Apostolou-Dionissis Bellas – Audi 80 GTE/1975

Regularity: Spyros Tzortzoglou-Aliki Papagianni – Morgan/1968

2003

Sporting: Fragkiskos Stafylopatis-Paul Brace – Porsche 911 R.S/1973

Regularity: Giannis Katsaounis-Alexandros Drouliskos – Ford Mustang Shelby 350/1965

2004

Sporting: Jari Laaksonen-Jari Kristeri – Volvo 142S/1968

Regularity: Giorgos Ioannidis-Evangelos Giannakos – Leyland Motors Mini MK II/1975

2005

Sporting: Jari Laaksonen-Jari Kristeri – Volvo 142S/1968

Regularity: Kostas Kontouzoglou-Marios Iliou – Porsche 911 Targa/1971

2006

Sporting: Alexandros Kikizas–Stavros Kikizas – Ford Escort RS 1600/1972

Regularity: Stelios Vanezos-Giorgos Kotzamanis – MG B Roadster/1973

2007

Sporting: Marco Bianchini – Emanuele Baldaccini – Lancia Stratos HF/1974

Regularity: Raffaello Raimondo – Marco Maria Calegari – Porche 356/1958

2008

Sporting: Marco Bianchini – Emanuele Baldaccini – Lancia Stratos HF/1974

Regularity: Stelios Vanezos-Giorgos Kotzamanis – MG B Roadster/1973

2009

Sporting: Vassileios Velanis-Ioannis Velanis – Ford Escort RS 1600/1974

Regularity: Stavros Stavrou-Kyriakos Christodoulou – Ford Escort/1976

2011

Sporting: Marco Bianchini – Emanuele Baldaccini – Lancia 037/1984 (tarmac)

Konstantinos Pitsos-Stelios Karapapazis – Toyota Celica 2000GT Rally/1979 (gravel)

Regularity: Apostolos Papanikos-Aristotelis Georgiou – Triumph GT6/1969

2012

Sporting: «Pedro»-Stefano Cirillo – Lancia 037/1984

Regularity: Iason Fotopoulos-Aristotelis Georgiou – Alfa Romeo GT Veloce 2000/1972



2013

Regularity: Iason Fotopoulos-Aristotelis Georgiou – Alfa Romeo GT Veloce 2000/1972

2014

Sporting: «Lucky» – Fabrizia Pons – Lancia 037/983

Regularity: Giannis Katsaounis-Mathios Mansolas – Porsche 911 2.0/1965

2015

Sporting: «Pedro» – Emanuele Baldaccini – Lancia Delta Integrale 16V/1990

Regularity: Spyros Moustakas-Nikos Moustakas – Alfa Romeo Alfasud/1978

2021

Regularity: Christian Crucifix – Antonio Caldeira – Porsche 911 S/1985

2022

Sporting: Konstantinos Pitsos-Stelios Karapapazis – Ford Sierra Cosworth 4x4

Legends: Epameinondas Karanikolas-Giorgos Kakavas – Ford Escort RS Cosworth

Regularity: Christos Chatzikonstantinou – Manolis Dimakareas – VW Golf 2

2023

Sporting: Marty McCormack – Barney Mitchell – Ford Escort MKII

Legends: Andreas Christodoulakis-Stavros Anamolidis – Subaru Legacy 4WD Turbo

Regularity: Athanasios Ntzoumanis-Vasilis Tsompanidis – Lancia Fulvia Coupe 1,3S



## APPENDIX A



### Trail Track GPS car tracking system

During the rally will be a GPS safety car tracking system.

**Warning:** The installation cable should be properly prepared by the crew and connected to the vehicle's power supply **BEFORE** they arrive for the initial technical inspection.

#### Power cable installation

The GPS Tracking System needs a reliable source from 6 to 28 V DC. The maximum consumption in no case exceeds 110mA at 12,6V.

It should be fused by an independent blade tape fuse 3A – 5A (maximum) or similar quality mounted on the cable in the battery side. Have spare fuses available in case they are needed.

The grounding / negative can be fused in any capable grounding point, provided that the isolation switch does not interrupt the negative supply.

The power supply should be continuous without interruptions

The GPS tracking system has a battery in it, that remains charged by the car's electric system. It serves as a spare power supply in case of accident, when the electric supply is stopped. (e.g. battery is destroyed or displaced, general switch etc).

**Warning:** The tracking system must be connected only after being placed in the final position and plugged to the supply. In that way ensured that the tilt, acceleration and knock sensors are properly set.





The cable (positive and negative pole) should end over the dashboard at the right pillar of the front part of the cage with an excess of 50 cm to facilitate the connection.

The cable should be red for the positive (+) and black for the negative (-) pole and multi wire flexible, at least 2x1,5mm<sup>2</sup>.

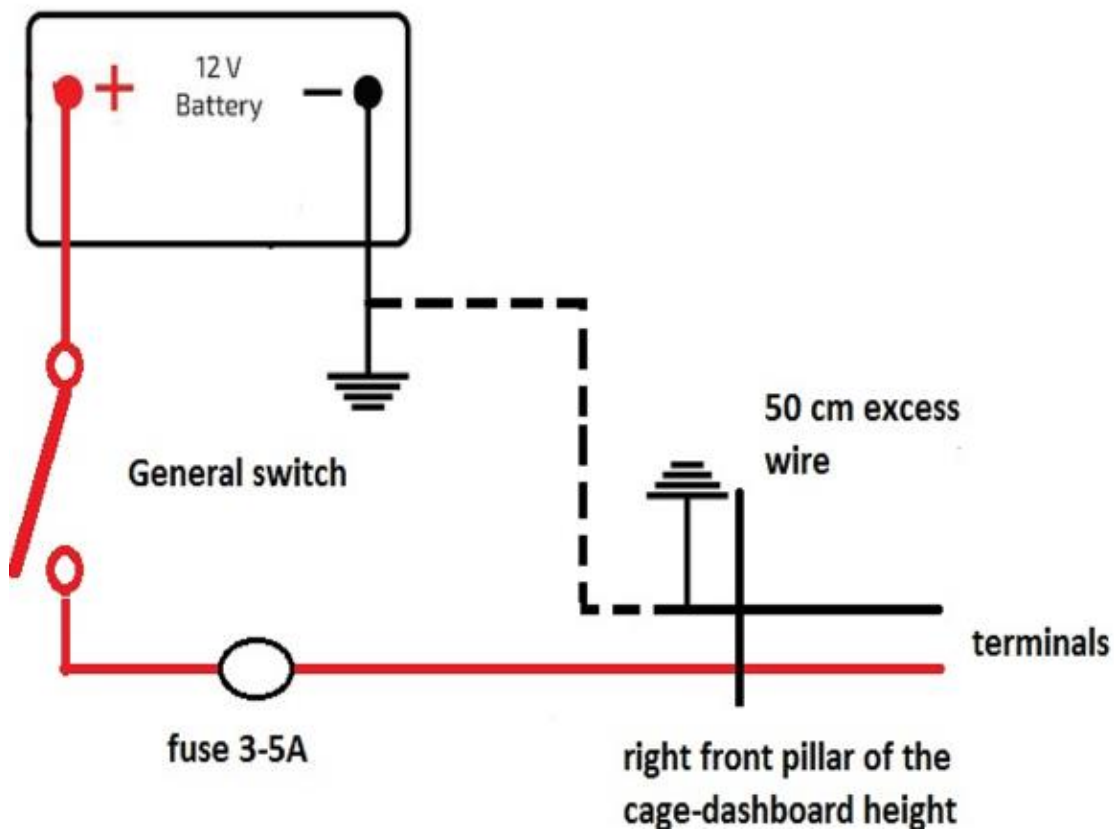

At the end of the cable there shall be fully insulated female blade-type terminals. 6.3X0.8mm



During installation, the harness should be routed away from the engine compartment and the ignition or generator wiring of the car and ensure that it is protected from edges, etc.



The GPS should be placed on the right pillar of the front part of the safety cage.  
 GPS dimensions are: 150mmX90mmX45mm. The GPS has holes to be retained with tire ups.